



**WITH YOU
SUCCESS TOGETHER**



VMX SERIES
Vertical Machining Center



HEADQUARTERS
No. 186, Yong Chi Road, Taipei, Taiwan.
Tel: +886-2-2763-9696
Fax: +886-2-2768-0636/37/39
www.ffg-tw.com
E-mail: chairom@fairfriend.com.tw



FEELER MACHINE TOOLS DIVISION
No. 12, Jingke Rd., Nantun Dist., Taichung City, Taiwan
Tel: +886-4-2359-4075
Fax: +886-4-2359-4873
www.feeler.com
E-mail: sales@feeler.com



Website



Facebook



22.04.1000.S661000001



VMX-580APC

VMX-580/760

Whether you require in high precision parts machining or general mold making, FEELER's new VMX Series Vertical Machining Centers offers unbeatable dependability.

The VMX Series is a well-engineered high precision unit, ideal for various precision industrial requirements.

Vertical Machining Center Provides State-of-the-art Efficiency For Increased Profitability

VMX-820APC

VMX-1650

VMX-820/1020

VMX-1100/1300

- Ideal machine model for high speed cutting market.
- Machine is equipped with direct drive spindle, which performs good rigidity.
- X/Y/Z axis can be equipped with linear guide or Z axis with box way to meet different processing purposes.
- Human friendly design, sleek front door and big side windows (door width: 1100mm) for convenient cleaning and easy maintenance.

Perfected Structure Design Brings You Lifetime Accuracy, Rigidity And Stability !

The machine structure and major parts are manufactured from Meehanite cast iron for outstanding material stability and guaranteed long-term deformation-free performance.

Spindle head stock is with one-piece design to increase 5% rigidity.

- Z axis is equipped with roller type line guides to enhance cutting rigidity.
- 634mm span of guideways on Y axis and 370mm span on Z axis guarantee superior stability for saddle and spindle head travel.

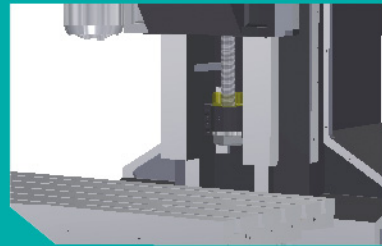

Z axis is also available with boxway(OPT.)

Z axis travel is extended to 560mm.(OPT : 635mm)

The column bottom is specially designed with A-shaped structure.

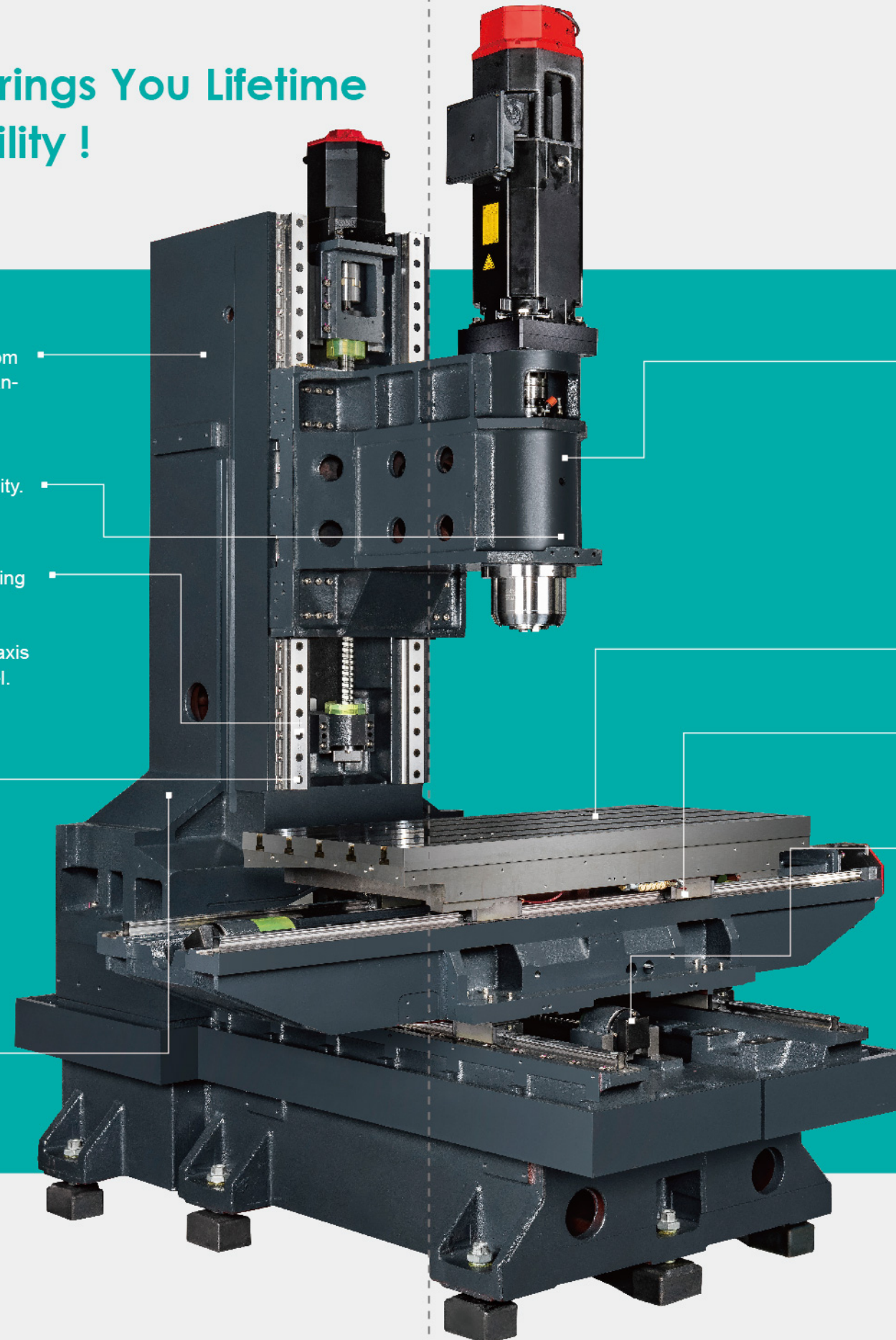

Equipped with 12,000 DDS spindle.(OPT 15,000 rpm)

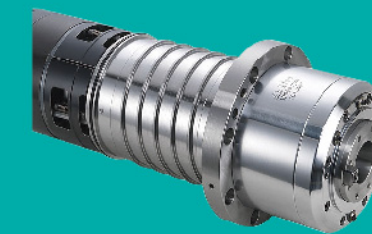

Max. table loading is 800kg.

Outstanding machine structure, combined with high speed servo system, allows rapid traverse up to 40 m/min.

Ballscrews are driven by DDS motor per-tensioned to ensure accuracy and eliminate positioning errors.

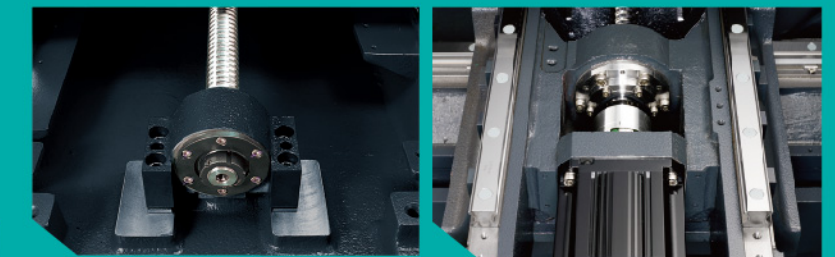

*The above specification is for VMX-820/1020

Machine Features



Dependable, Efficient ATC

- FEELER's ATC designs are all subjected to 1 million cycles of continuous tests for durability and stability to assure maximum dependability of operational performance.
- It's available with 30T magazine(opt.) and is able to load into HQ container.



Powerful Flushing System

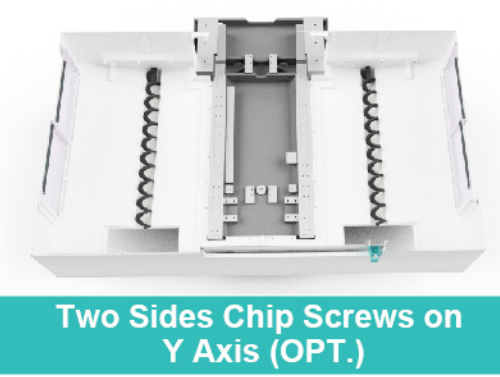

Two Sides Chip Screws on Y Axis (OPT.)

It can quickly and efficiently remove metal chips.

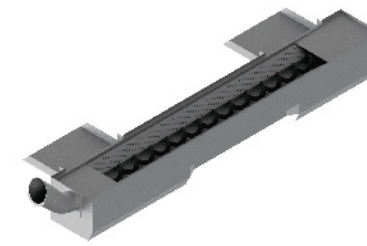

Screw Type Chip Conveyor (OPT.)



Chip Conveyor (OPT.)
water tank and chip tank are separated for easy cleaning.



Z axis with 45mm roller type linear guide.

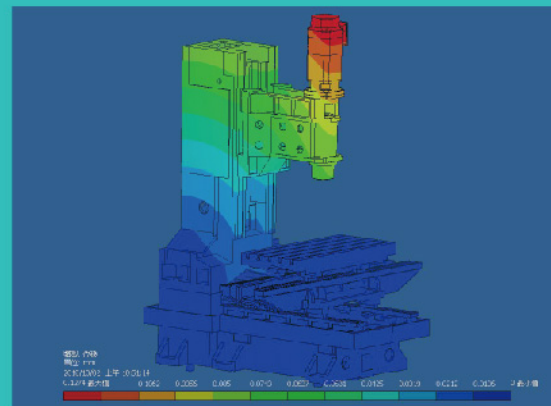

FEM ANALYSIS

FEELER's machine structure is designed and analyzed using advanced Finite Element Analysis software for dynamic simulation and structural analysis. The design method assures optimum structural rigidity, machine accuracy and reliability.



Rubber seals are mounted at the EC cabinet door for optimal enclosure.

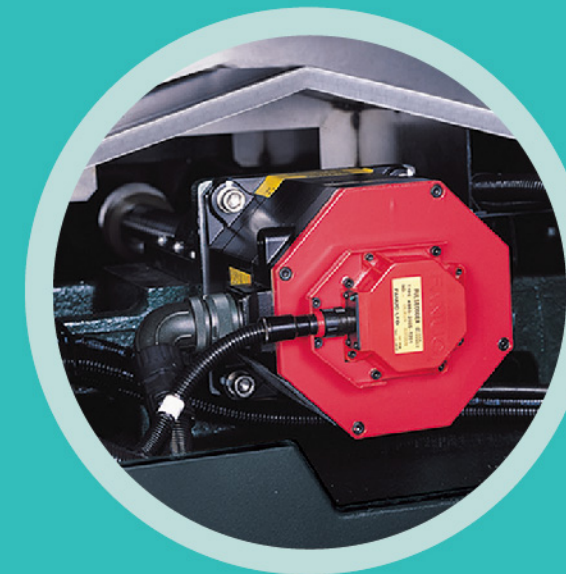

Rear installation of the Y axis servo motor provides a convenient maintenance space.



Air-gun and coolant-gun fittings for your convenience.(OPT.)

6-Second APC Changing Time. (VMX-580APC)

Compact design of the VMX-Series occupies the least amount of floor space and contributes to space saving.

X and Y axis are equipped with roof-type telescopic covers for rapid traverse. The roof-type telescopic cover is uniquely designed for metal chips to fall off easily. Z axis is also equipped with a telescopic cover to protect linear guideways and ballscrews.

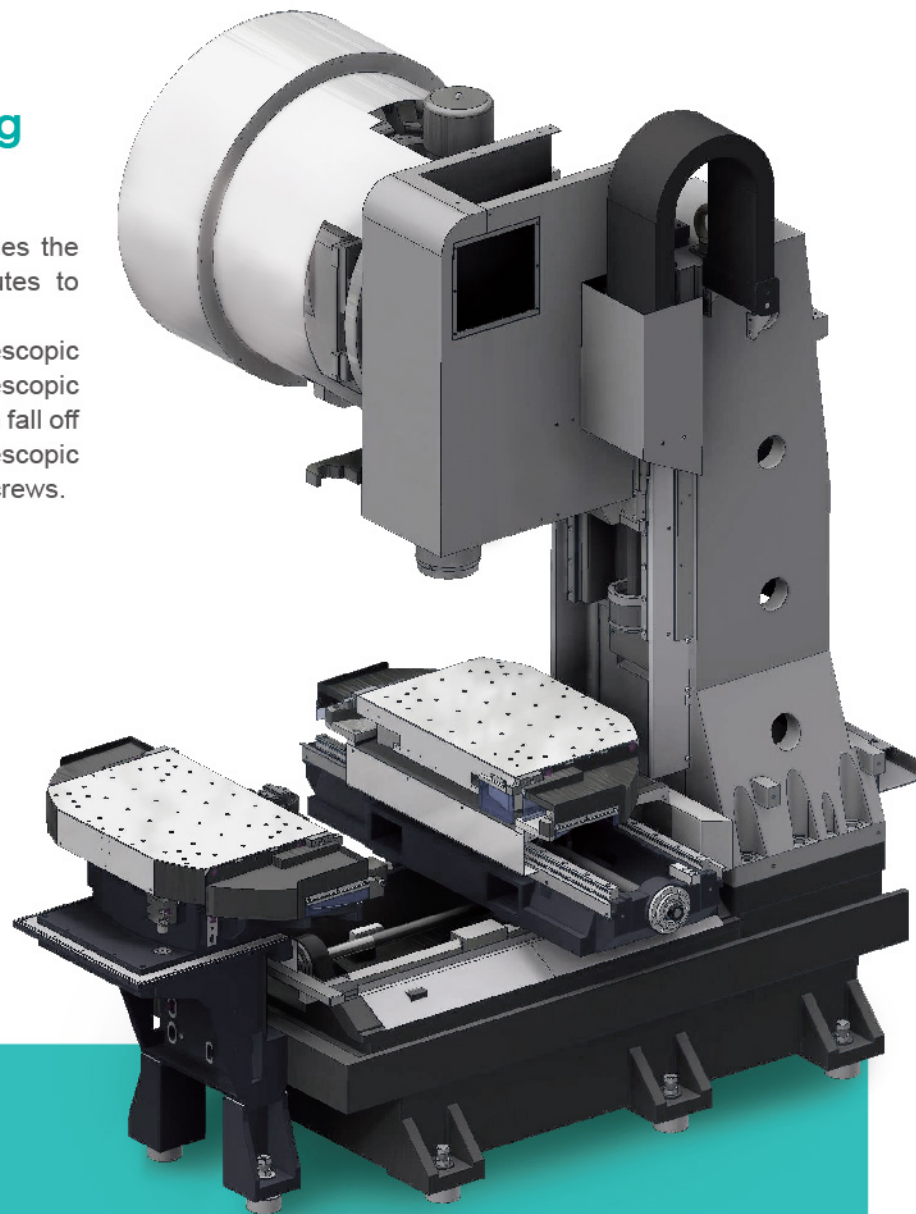
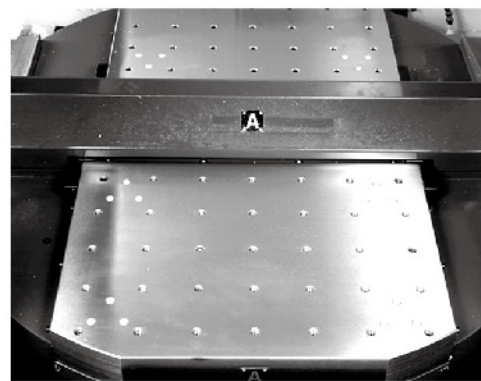

Automatic Pallet Changer

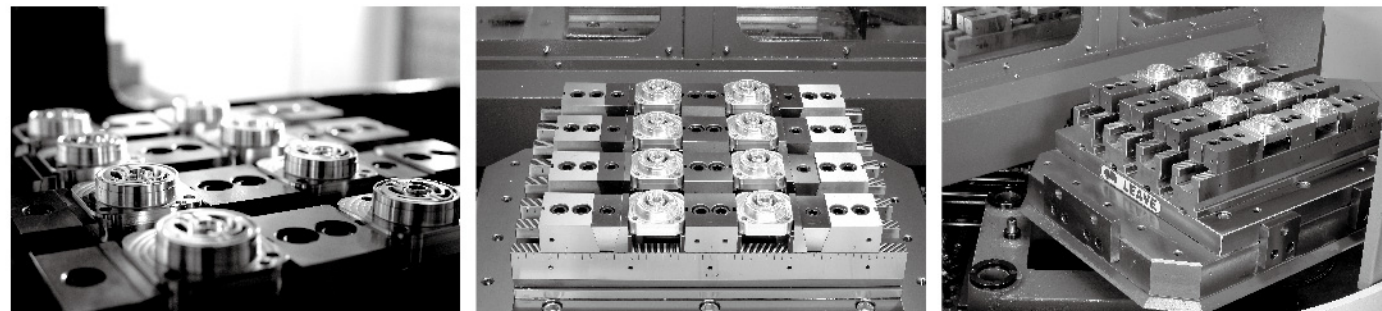

Utilizing the Hydraulic Rotary Mechanism, VMX series can perform fast, stable, and reliable pallet changing.

FOCUS ON High Speed Cutting Market

- **Model Chosen**
Based on workpiece to choose high C/P value and good efficiency machine model to meet processing requirements.
- **Engineering Analysis**
Assisting to do cycle time, tooling and fixture evaluation.
- **Automation/Turn-key Project**
Assisting automation /Turn-key project evaluation and engineering application.

Model	VMX-1020
Using Tool	D80 6 Edges Face Mill
Dry Cutting	S45C

| Face Milling |

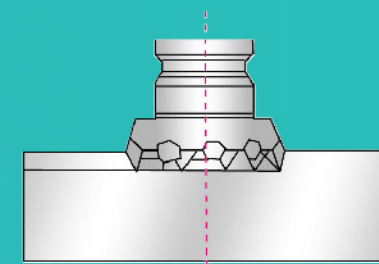

Removing q'ty / min. 312(CC/min)

| Drilling |

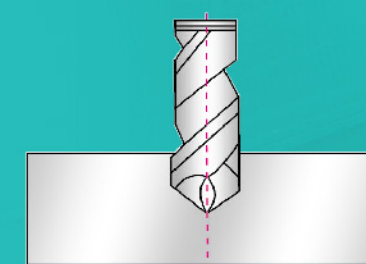

Diameter of drill 40(mm)

| Tapping |

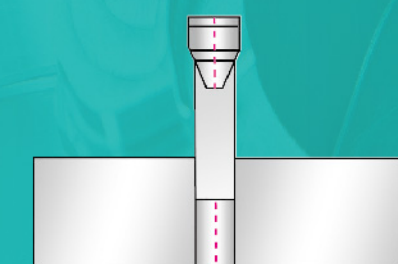

Specification of tapping M24*3CM

A Good Partner of Production

FEELER INTELLIGENCE MONITORING (OPT.)

Thermal Compensation

After long term operation and workpiece machining, it would cause thermal deformation of machine structure to affect accuracy. According to the information of temperature changing, which are located in machine structure (around 4~8 locations) and 8 channels Thermal compensation system, which is developed by Feeler R&D team to calculate the differences of temperature to do thermal compensation. Hence, the machining deviation accuracy will be restrained under 0.02mm to increase machining quality.

Features

- Establish independent temperature rise and thermal displacement compensation technology
- Self-developed 8-channel thermal compensation card
- Solve the problem of thermal displacement of machines
- Thermal deviation can be controlled within 0.02mm

Existing Cases

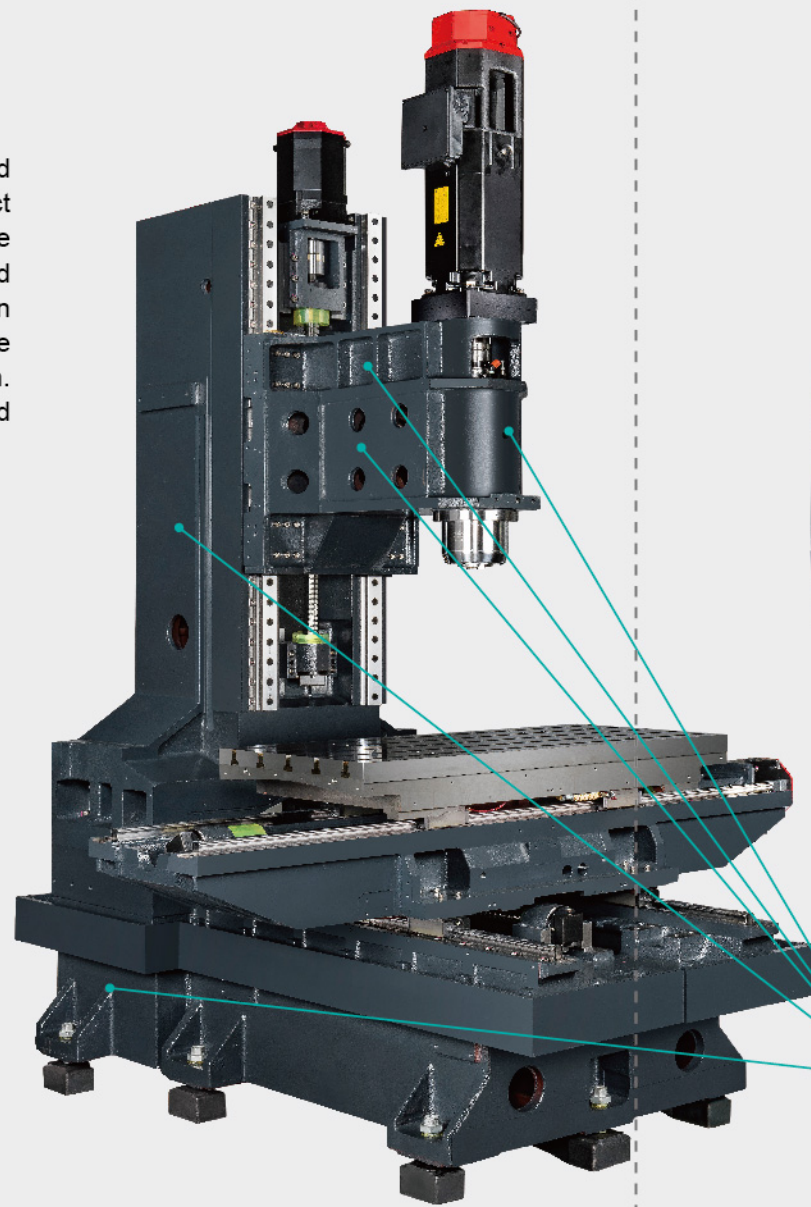
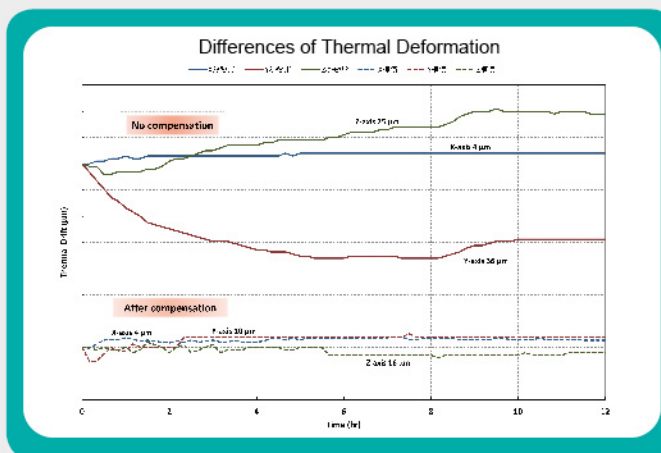

Temperature Sensor Place(sample)



Spindle Torque/Motor Drawing

◆ FANUC ai18/12000 for spindle 12000rpm

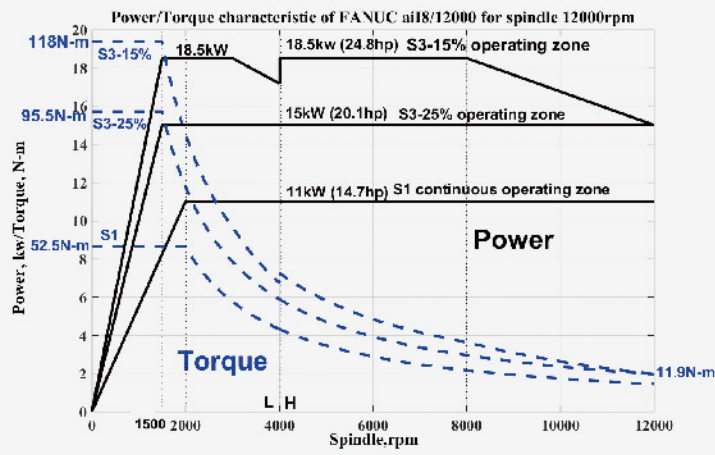

◆ FANUC ai18/15000 for spindle 15000rpm

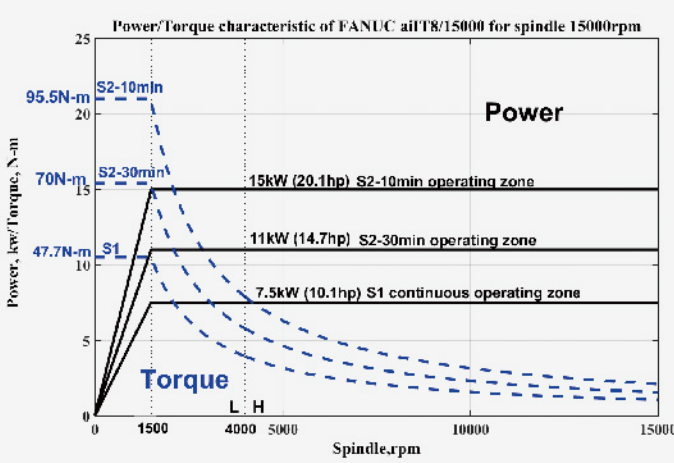

◆ FANUC ai15/12000 for spindle 12000rpm

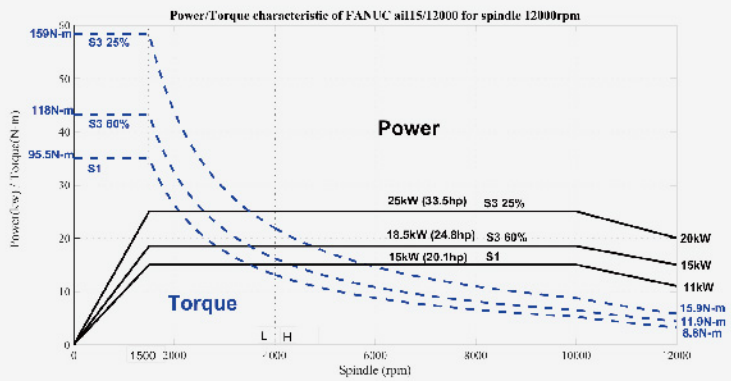

◆ FANUC ai15/15000 for spindle 15000rpm

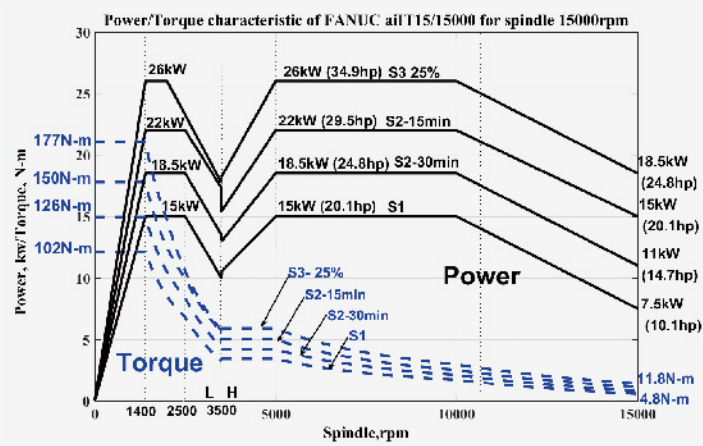

◆ MITSUBISHI SJ-DG11/120 for spindle 12000rpm

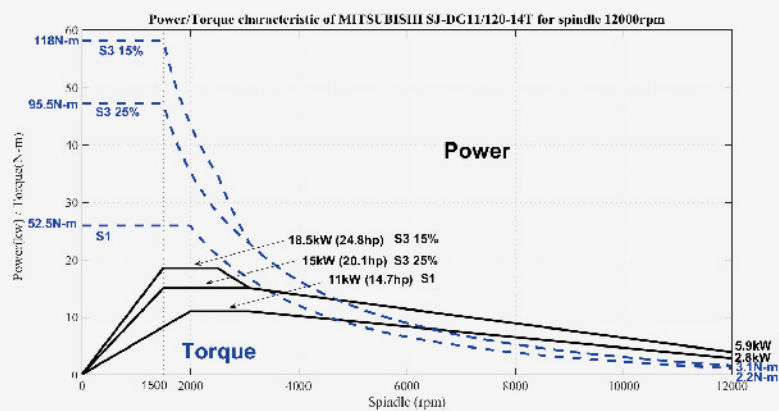

FEELER Self-Developed HMI (For Mitsubishi Controllers)



Various information such as coordinates, spindle load, three-axis load, feed rate, machining programs and tool data is sorted and integrated in on single screen, Well organized and complete data presentation leads to an enhancement of efficiency by 20%

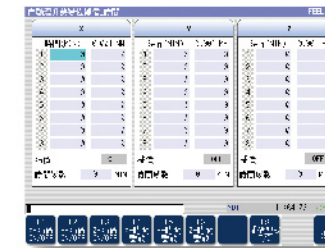

Five Machine Functions

- Intelligent Auto Federate Adjustment
- Auto Acceleration / Deceleration Adjustment
- Auto Thermal Expansion Compensation
- Multi Mode Processing Selection
- Intelligent Rigid Tapping

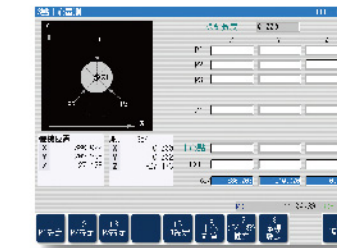

Trouble Shooting 3 items

- Tool arm Single Test
- Tool Arm Troubleshooting
- Rigid Tapping Troubleshooting

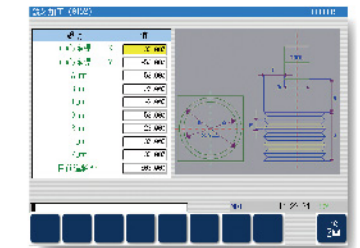

Five Machining Program Features

- APC Working Program Selection
- Variable Feed rate for deep Hole Drilling
- Wide threading
- Roundness machining
- Step hole machining

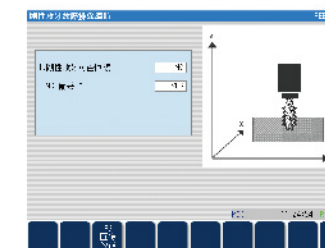

Four Measurement Features

- 4 Point Center Measurement
- 3 Point Center Measurement
- Edge Length Measurement
- Corner Coordinates Measurement

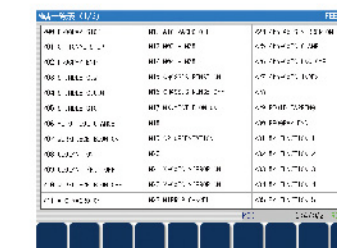

Five Diagnosis Features

- Machine Specifications Description
- PLC I/O diagnosis table
- Spindle Speed Record
- Advanced Maintenance Notice
- Machine PLC I/O Drawing



Five Other Functions

- M Code List
- T Code Search Program
- Quick Coordinate Positioning
- PLC Software Added
- Calculator

Machine Layout

◆ VMX-580/760

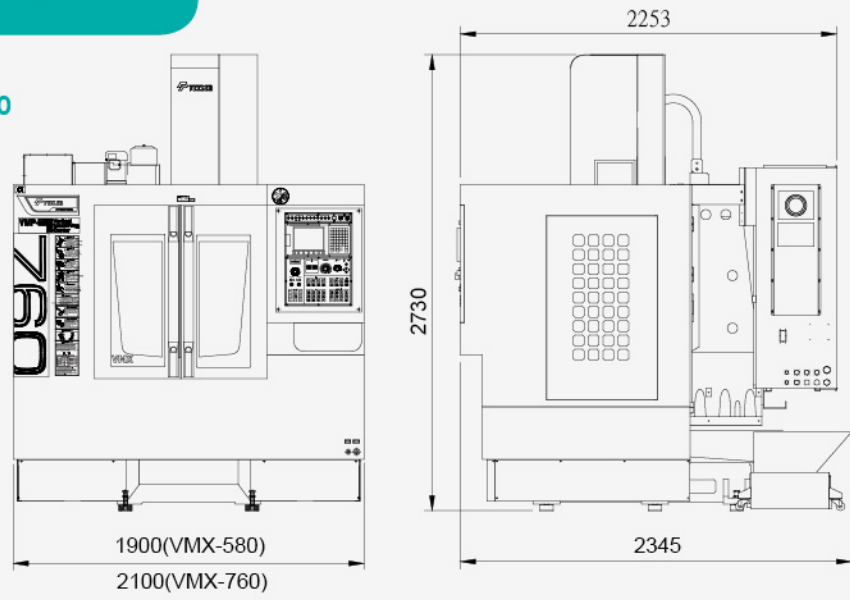

◆ VMX-580APC

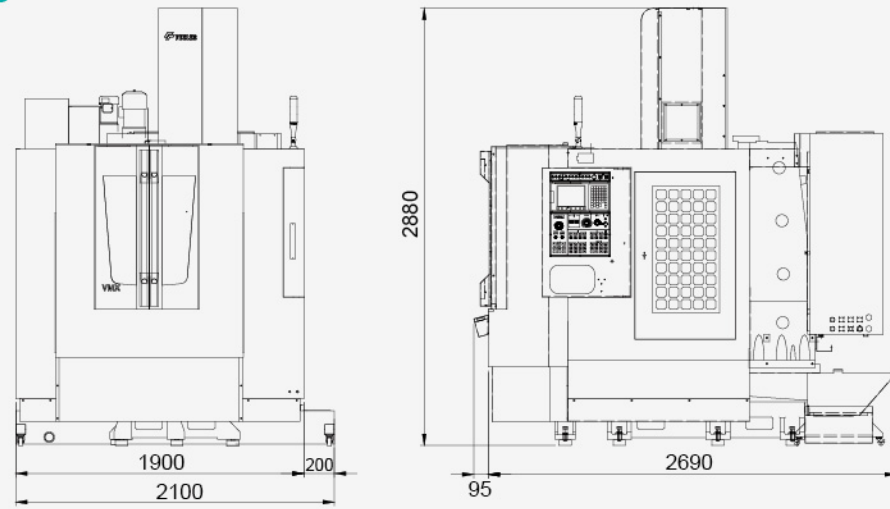

◆ VMX-820/1020

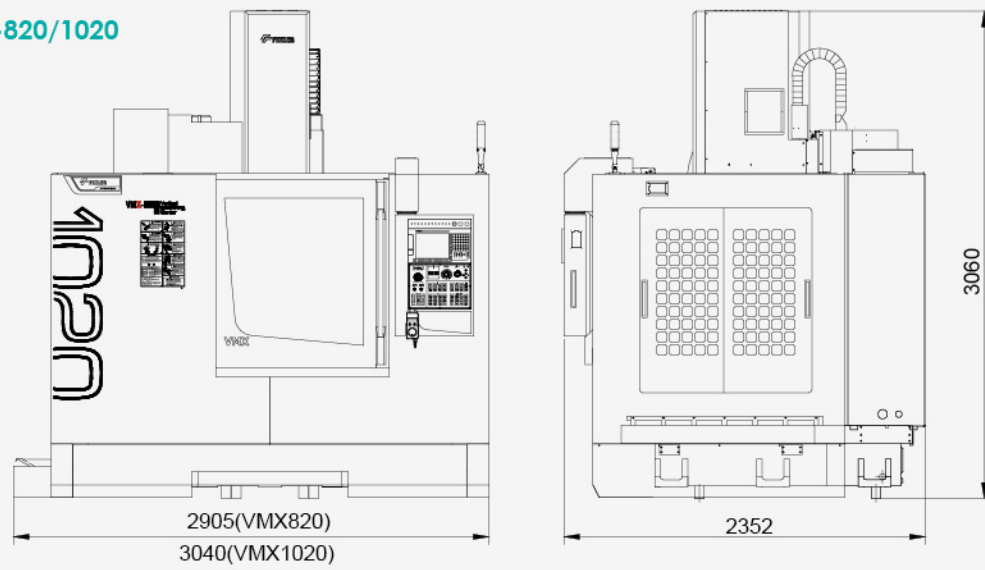

◆ VMX-820APC

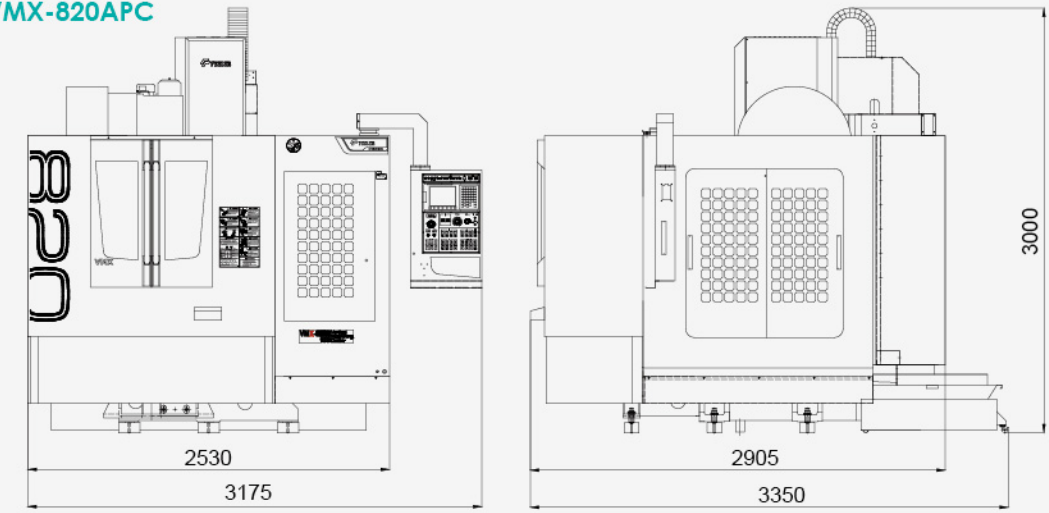

◆ VMX-1100

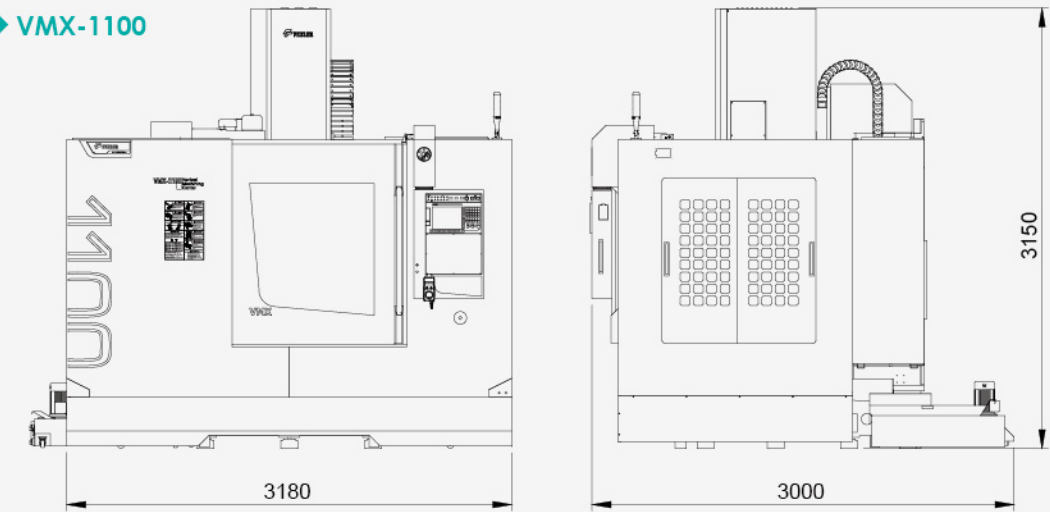

◆ VMX-1300

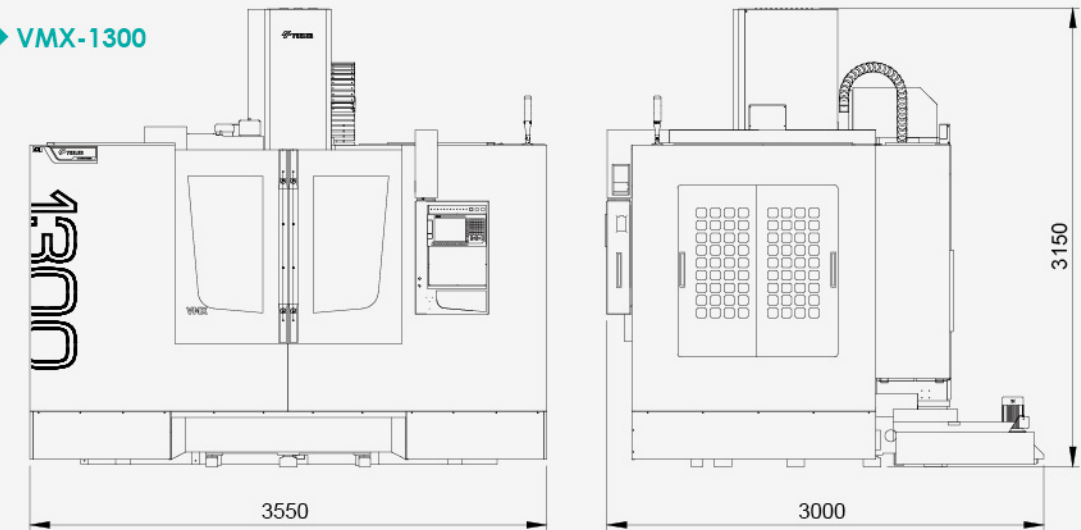

Machine Layout

◆ VMX-1650

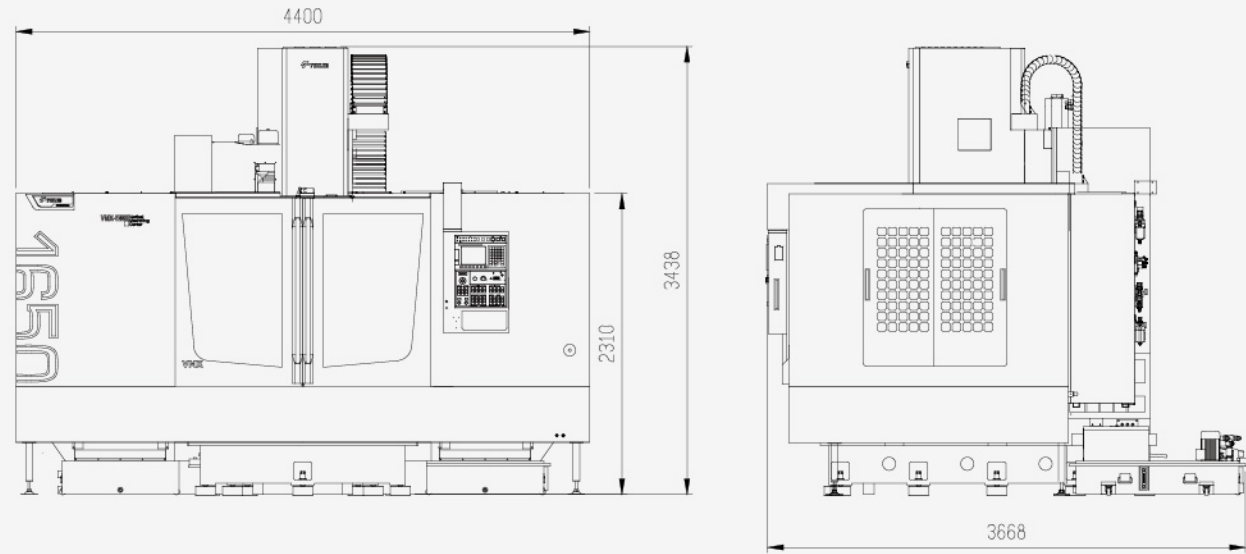

Working Table Dimensions

◆ VMX-580/760

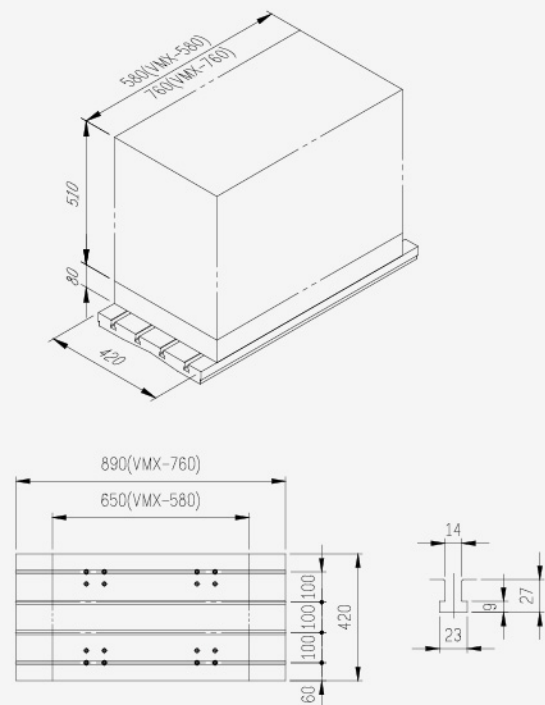

◆ VMX-580APC

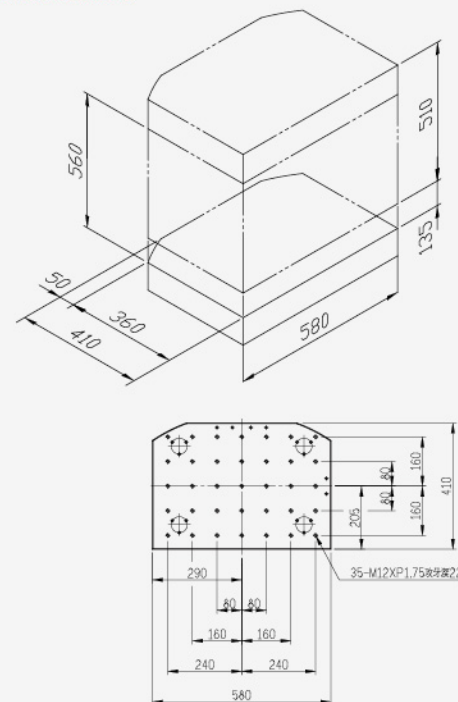

Working Table Dimensions

◆ VMX-820/1020

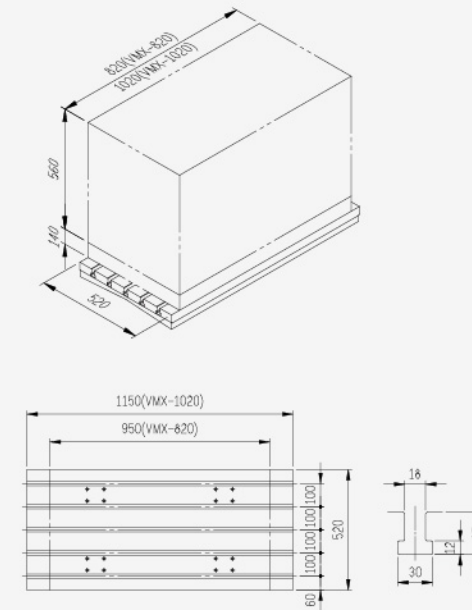

◆ VMX-820APC

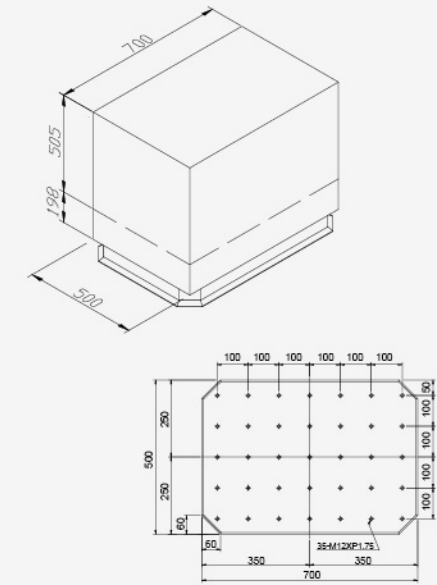

◆ VMX-1100/1300

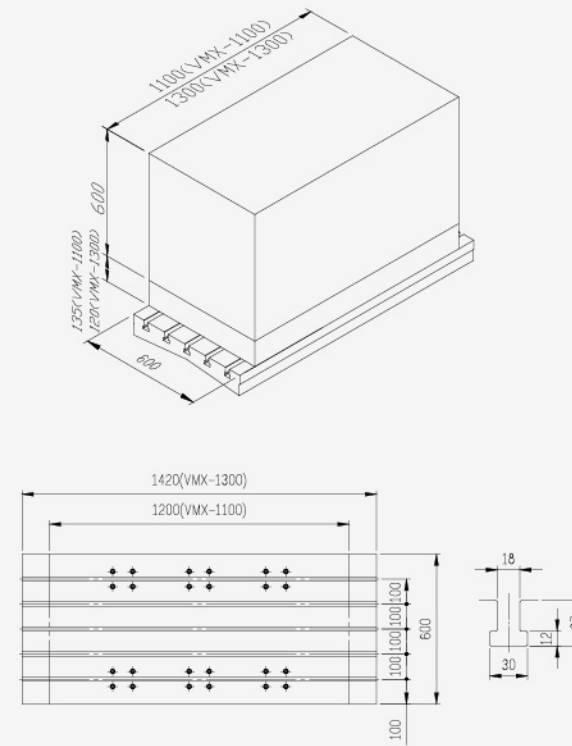

◆ VMX-1650

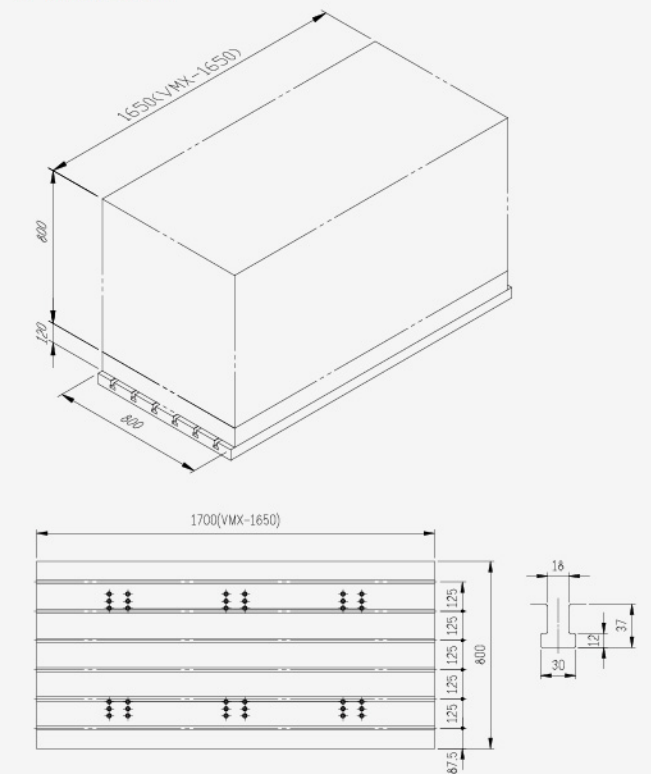

MACHINE SPECIFICATIONS

MODEL	Unit	VMX-580	VMX-580 APC	VMX-760	VMX-820	VMX-820 APC	VMX-1020	VMX-1100	VMX-1300	VMX-1650
TRAVEL										
X-Axis Travel	mm	580		760	820		1020	1100	1300	1650
Y-Axis Travel	mm	420			520			610		800
Z-Axis Travel	mm	510			560	505	560	600		800
Spindle Nose to Table Surface	mm	80~590	135~645	80~590	140~700	198~703	140~700	135~735	120~720	120~920
Spindle Center TO Column Surface	mm	455			560			660		882
Table Surface to Floor	mm	820	915	820	920	1025	940	960	975	1080
TABLE										
Table Dimensions	mm	650x420	580x410	890x420	950x520	700x500	1150x520	1200x600	1420x600	1700x800
Max.Loading Weight	mm	300	120	300	800	200	800	1500		1500
T-slots (W×NO.×P)	mm	14x4x100	35-M12xP1.75	14x4x100	18x5x100	35-M12xP1.75	18x5x100	18x5x100		18x6x125
SPINDLE										
Spindle Speed	mm	12000								
Spindle Taper	-	7/24 taper NO.40								
DIA. of Spindle	mm	ø60			ø70		ø70		ø70	
Spindle Motor (power requirements)	FANUC MITSUBISHI	Kw	11/18.5 (S1/S3_15%)	11/18.5 (S1/S3_15%) 7.5/15 (S1/S3_15%)	11/18.5 (S1/S3_15%)		11/18.5 (S1/S3_15%)		15/25 (S1/S3_25%)	15/18.5 (S1/S2)
FEED RATE										
X-Axis Rapid Traverse	m/min	48			40		36		36	
Y-Axis Rapid Traverse	m/min	48			40		36		36	
Z-Axis Rapid Traverse	m/min	32			30		24		24	
ATC (AUTOMATIC TOOL CHANGER)										
No. of Tools (Arm type)	-	20			24		24		24	
Pull Stud	-	P-40T (45°)			P-40T (45°)		P-40T (45°)		P-40T (45°)	
Max. Tool Weight	Kg	7			8		8		8	
Max. Tool Length	mm	250			300		300		300	
Max. Tool Diameter	mm	ø80			ø75		ø80		ø80	
Max. Tool Diameter (No Adjacent Tool)	mm	ø130			ø150		ø150		ø150	
Tool Changing Time (Tool-to-Tool)	sec	1.7			1.7		1.7sec/60Hz		1.7sec/60Hz	
OTHER										
Floor Space	mm	1900X2345	1900X2690	2100X2345	2905X2352	3175X3350	3040X2352	3180x3000	3550X3000	4400×3668
Machine Weight (N.W.)	Kg	3000	3900	3300	5800	7500	6300	6800	7300	13000
Max. Machine Height	mm	2730	2880	2730	3060	3000	3060	3150	3150	3438
Power Capacity	KVA	30			30		30		30	
Air Source	bar	6~8			6~8		6~8		6~8	
APC(AUTOMATIC PALLET CHANGER)										
Change Time	sec	-	6	-	-	10	-	-	-	-
APC Type	-	-	Rotary	-	-	Rotary	-	-	-	-

* Specifications are subject to change without prior notice.

MACHINE ACCESSORIES

NO	Features	VMX-580	VMX-580 APC	VMX-760	VMX-820	VMX-820 APC	VMX-1020	VMX-1100	VMX-1300	VMX-1650
1	Full Enclosure	●	●	●	●	●	●	●	●	●
2	Work Lamp_One Group	●	●	●	●	●	●	●	●	×
3	Work Lamp_Two Groups	○	○	○	○	○	○	○	○	●
4	3 Color Signal Light	●	●	●	●	●	●	●	●	●
5	Rigid Tapping	●	●	●	●	●	●	●	●	●
6	3-Axis Pre-tensioned Ballscrew	●	●	●	●	●	●	●	●	●
7	Automatic Lubrication System	●	●	●	●	●	●	●	●	●
8	Spindle Air Blast	●	●	●	●	●	●	●	●	●
9	Spindle Splash Ring	●	●	●	●	●	●	●	●	○
10	Water Tank Front Position	×	×	×	●	×	●	○	○	○
11	Water Tank Rear Position	●	●	●	○	●	○	●	●	●
12	Water-Oil Separator	×	×	×	●	●	●	●	●	●
13	Oil Skimmer	○	○	○	○	○	○	○	○	○
14	Air Gun Interface	●	●	●	●	●	●	●	●	●
15	Coolant Gun	●	●	●	●	●	●	●	●	●
16	Flushing_Rear Y axis	●	●	●	×	●	×	×	×	●
17	Flushing System	●	●	●	●	●	●	●	●	●
18	Spindle oil Cooler	●	●	●	●	●	●	●	●	●
19	High Pressure Pump	○	○	○	○	○	○	○	○	○
20	CTS & Filtering System(OPT:Top roof)	○	○	○	○	○	○	○	○	○
21	Top Roof	○	○	○	○	●	○	○	○	○
22	Magazine Capacity 20T	●	●	●	×	×	×	×	×	×
23	Magazine Capacity 24T	○	○	○	●	●	●	●	●	●
24	Magazine Capacity 30T	×	×	×	○	○	○	○	○	○
25	Magazine Capacity 40T	×	×	×	○	○	○	○	○	○
26	Dust-Tight Electrical Cabinet	●	●	●	●	●	●	●	●	●
27	Heat Exchanger for Electrical Cabinet	●	●	●	●	●	●	●	●	●
28	Air Conditioning for Electrical Cabinet	○	○	○	○	○	○	○	○	○
29	Direct-Drive Spindle_12000rpm	●	●	●	●	●	●	●	●	●
30	Direct-Drive Spindle_15000rpm	○	○	○	○	○	○	○	○	○
31	Linear Scale on X/Y/Z Axis	○	○	○	○	○	○	○	○	○
32	Auto Tool Length Measurement	○	○	○	○	○	○	○	○	○
33	Auto Workpiece Measurement	○	○	○	○	○	○	○	○	○
34	Chip Screw+Chip Cart	○	○	○	○	○	○	○	○	○
35	Chip Conveyor+Chip Cart	○	○	○	○	○	○	○	○	○
36	4th Axis Interface Prepration	○	○	○	○	○	○	○	○	○
37	Auto Power off	○	○	○	○	○	○	○	○	○
38	3 Axes Roller Type Linear Guideway	○	○	○	○	○	○	○	○	●
39	Ethernet Interface	●	●	●	●	●	●	●	●	●

● Standard ○ Optional × N/A